

# SSDB-E4 | RETROFIT DRY SEAL

- FOR QUICK CONVERSION FROM GLAND PACKING
- FOR WORN-OUT SHAFTS
- CAN TOLERATE 3.8mm SHAFT RUNOUT / ECCENTRICITY & OUT OF SQUARE PAD FLANGE
- LOW HEADROOM REQUIRED
- CAN BE EASILY ADOPTED TO FIT ON ANY EXISTING PAD FLANGE
- STEAM STERILIZATION OPTION AVAILABLE

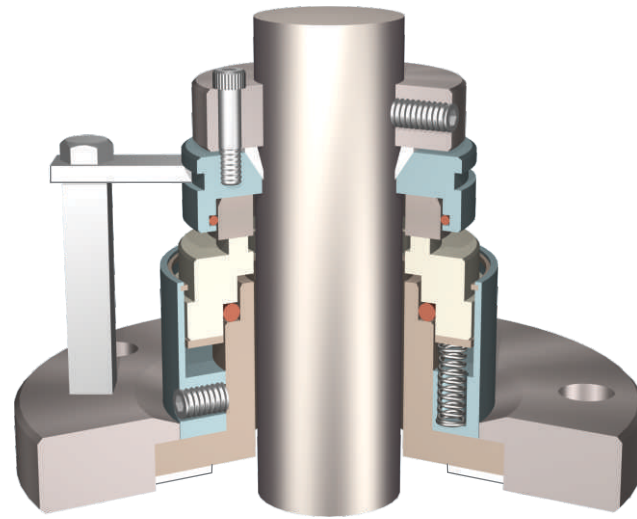

SSDB-E4 seals are dry running retrofit seals meant for quick conversion of old gland packed agitators. Because of stationary spring design, it can tolerate out of square pad flange. Since there is no closely fitting sleeve, the seal can be installed easily on worn out shafts. SSDB-E4 seals can also be retrofitted on glass lined reactors.

### APPLICATIONS :

- FERMENTORS
- HORIZONTAL MIXERS
- GLAND PACKED REACTORS
- GLASS LINED REACTORS

### INSTALLATION DIMENSIONS

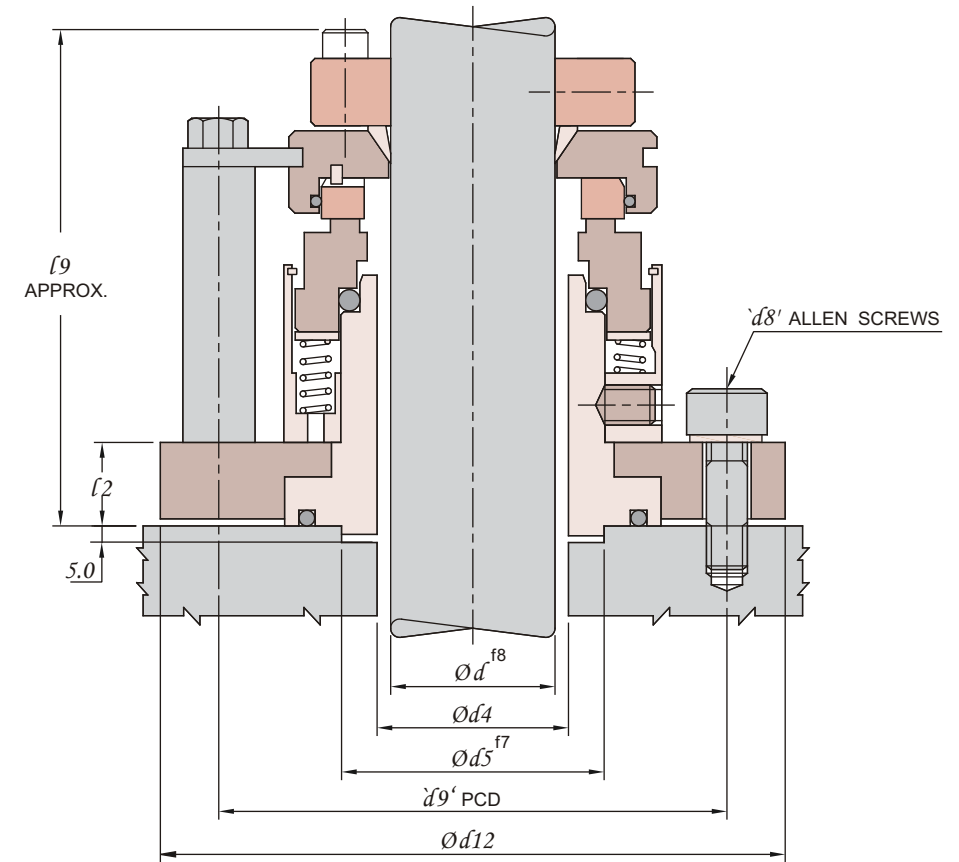

SIZE CODE	d'	d4	d5	d8	d9'PCD	d12	l2	l9	SIZE CODE	d'	d4	d5	d8	d9'PCD	d12	l2	l9
0250	25.0	30.0	47.5	4,M8	85.00	100.0	17.0	110.0	0900	90.00	95.00	115.0	4,M10	157.5	180.0	21.0	125.0
0300	30.0	35.0	47.5	4,M8	85.00	100.0	17.0	110.0	0950	95.00	100.0	120.0	4,M10	162.5	185.0	21.0	125.0
0350	35.0	40.0	53.5	4,M8	92.50	107.5	17.0	110.0	1000	100.0	105.0	127.5	4,M12	172.5	195.0	21.0	125.0
0400	40.0	45.0	60.0	4,M8	97.50	112.5	17.0	110.0	1050	105.0	110.0	132.5	6,M12	185.0	207.5	21.0	125.0
0450	45.0	50.0	67.5	4,M8	102.5	117.5	17.0	115.0	1100	110.0	115.0	132.5	6,M12	185.0	207.5	21.0	125.0
0500	50.0	55.0	72.5	4,M8	115.0	130.0	17.0	120.0	1150	115.0	120.0	140.0	6,M12	187.5	210.0	21.0	125.0
0550	55.0	60.0	72.5	4,M8	115.0	130.0	17.0	120.0	1200	120.0	125.0	145.0	6,M12	195.0	217.5	21.0	130.0
0600	60.0	65.0	80.0	4,M8	125.0	140.0	17.0	120.0	1250	125.0	130.0	152.5	6,M12	202.5	225.0	24.0	130.0
0650	65.0	70.0	86.0	4,M10	132.5	152.5	21.0	120.0	1300	130.0	135.0	162.5	6,M12	207.5	230.0	24.0	130.0
0700	70.0	75.0	92.5	4,M10	137.5	157.5	21.0	120.0	1350	135.0	140.0	162.5	6,M12	207.5	230.0	24.0	130.0
0750	75.0	80.0	97.5	4,M10	145.0	165.0	21.0	120.0	1400	140.0	145.0	165.0	6,M12	215.0	237.5	24.0	140.0
0800	80.0	85.0	105.0	4,M10	150.0	170.0	21.0	125.0	1450	145.0	150.0	177.5	6,M12	220.0	242.5	24.0	140.0
0850	85.0	90.0	105.0	4,M10	150.0	170.0	21.0	125.0	1500	150.0	155.0	185.0	6,M12	227.5	250.0	24.0	145.0

### LIMITING PARAMETERS

PRESSURE	TEMPERATURE	SPEED
FULL VACUUM TO 6 BAR	- 40° C TO 150° C	1 m/sec

### MATERIALS

METAL PARTS	SEAL FACES		ELASTOMERS
	ROTARY	STATIONARY	
SS316 SPECIAL MOC ON REQUEST	CARBON SIC	SIC, TC	VITON, EPR, SILICON PTFE, GFT, STV AFLAS, FFKM